

Poteau ATLAS Renversable

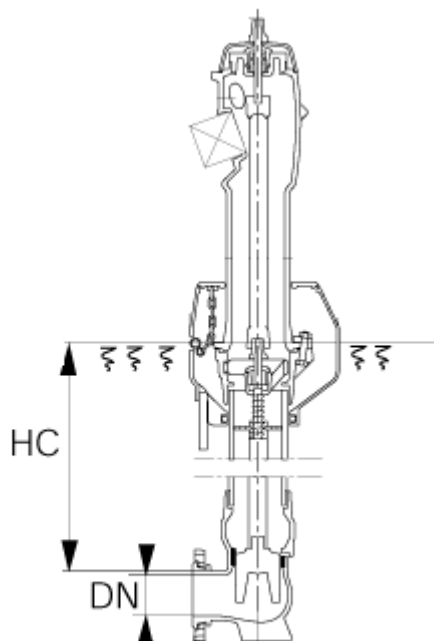

Produits complémentaires, Variantes, Accessoires ...

■ [Poteau ATLAS Non Renversable](#)

DN (mm)	Hc m	Type	Particularité	Prise symétrique Nbre x DN	Fermeture Nbre de tours	MASSE kg	Références
80				1xDN65	13	90	RYA80ABBAC
80	1	R	boite coudée	1xDN65_2xDN40	13	90	RYA80ABBBC
150				1xDN65_2xDN100	17	164	RYB15ABBDC
80	1.25	R	boite droite	1xDN65	13	96	166694
150				1xDN65_2xDN100	17	164	RYB15APDCD

R : Renversable (Poteau d'incendie)

1 prise : position **Frontale_2 prises** : position **latérale**